

Raspberry Pi GPIO Connector  
Male Extra Long (19mm) 20x2 Header Pins

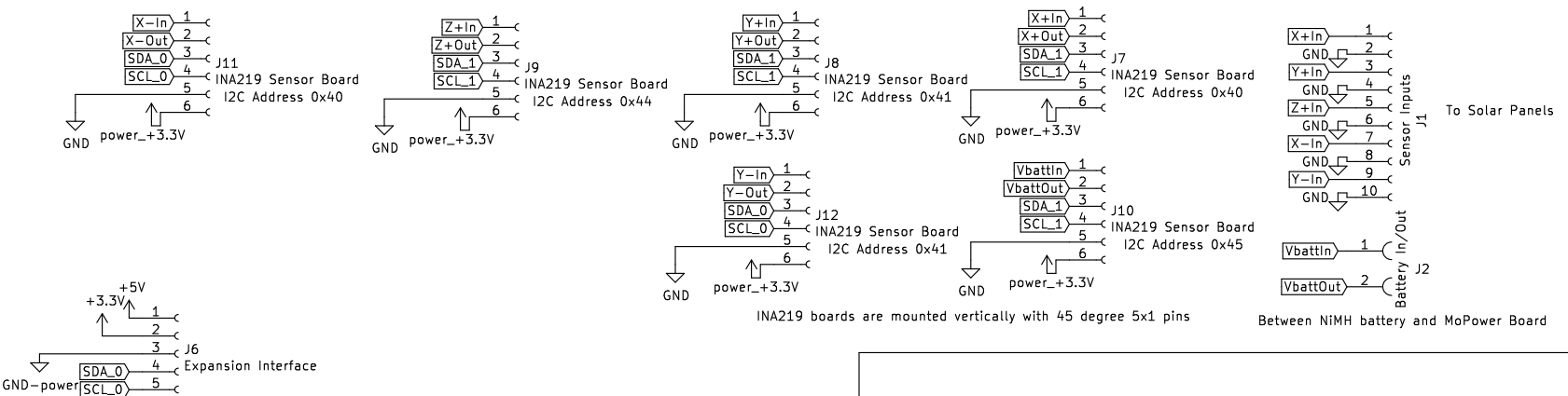

See <https://github.com/alanjohnston/cubesatsim>  
 Sheet: /  
 File: cubesatsim\_solar.sch  
**Title: AMSAT CubeSat Simulator Solar Panel Board**  
 Size: USLetter Date: / /  
 KiCad E.D.A. kicad (5.0.1)-4  
 Rev: Beta1  
 Id: 1/1